

Varenummer: 0109069
 Beskrivelse: Seeger låsering AS 52X3.0
 Fjederstål
 Note: Monteres med ZGA tang

Mål

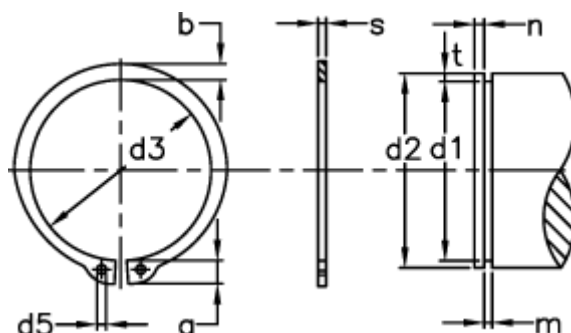

a max	= 8.2	d5 min	= 2.5	s	= 3.00
AN mm ²	= 238.0	FN kN	= 39.70	t	= 1.50
B	= 2.25	FRg kN	= 26.0	Tang	= ZGA-3
b	= 5.2	FR kN	= 165.0	tol	= -0.08
Betegnelse	= AS 52	g	= 2.5	tol	= +0,39 -0,90
d1	= 49.0	m min	= 3.15	tol	= -0.25
d2	= 52	n abl x 1000	= 10	vægt kg/1000	= 15.40
d3	= 47.8	Nominel træk	= 4.5		